

SMALL BLOCK

360 LA-X

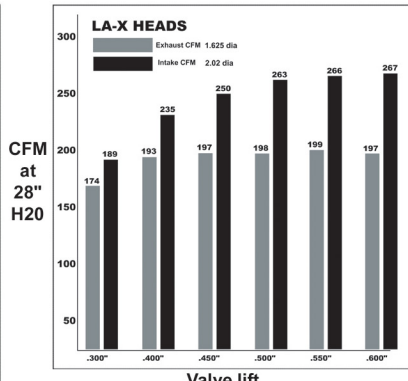
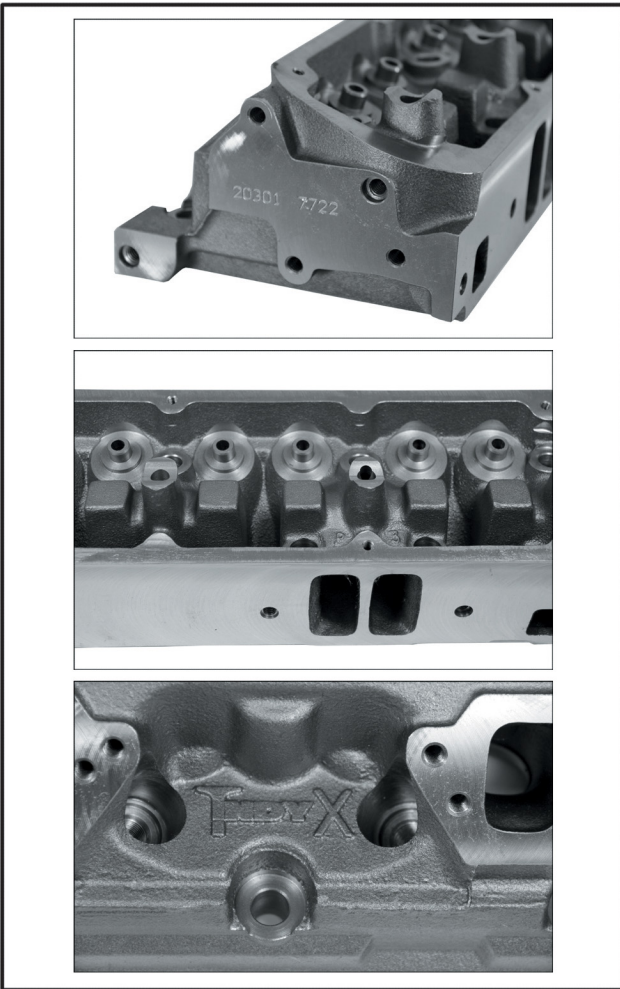

The 360 LA-X Heads From Indy are a true LA head. The LA-X utilizes 100% LA style parts including, shaft mounted rockers, LA bolt pattern intake manifolds, and valve covers. The big advantage to the LA-X head is the dual exhaust bolt pattern. Both stock LA as well as W-2 bolt patterns are machined into the head allowing for a much larger header selection.

Standard Assembled Heads Feature:

- Brand new cast iron LA-X castings.
- High flow 5/16 stainless valves 1.92x1.625.
- 2.02 and 2.055 intake valves available.
- .525 lift valve springs (.600 lift available).
- 3 angle valve job.
- Chrome moly retainers.
- 7 degree locks.
- 179cc intake runner.
- 62cc combustion chambers.
- Upgrades and porting are available.

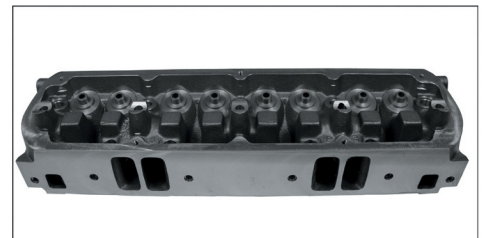
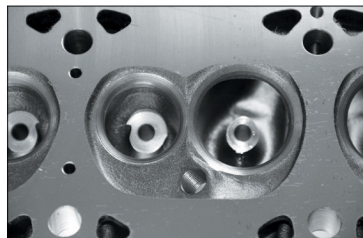

INDY T/A HEADS

340-360 1967-1992 Small Block Chrysler T/A Style Aluminum Head

Assembled with:

- 7 Degree locks
- 3 Angle valve job
- 175cc Intake volume
- .650 Lift valve springs
- Chrome moly retainers
- Thick wall rocker shafts
- 3/8" Rocker shaft stud kit
- Billet steel shaft clamp kit
- 63cc Combustion chambers
- Bowl porting and gasket match
- 2.055 x 1.625 Stainless steel valves
- Roller rocker arms (1.5 or 1.6 ratio)
- Billet aluminum fully adjustable offset
- With head bolts and pushrods

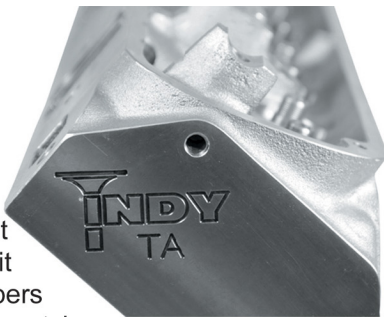

- The intake runner is never any better than its smallest cross sectional area, usually right beside the pushrod.
- The relocated push rod hole needs offset rockers to complete the wide intake port.
- The rocker shaft is moved and 440 rockers are used to relocate the pushrod.
- An age old problem with small block Chrysler engines is that the rocker arms are too close to the valve spring. 440 rockers fix this with more valve spring clearance.

Relocated Pushrod Hole



Port Width By Pushrod +.190" Wider Than Stock

Call: 317-862-3724 Fax: 317-862-6300 Web: indyheads.com Email: techline@indyheads.com

Hemi is a trademark of the Chrysler Corporation and is used for identification purposes only. Not legal for use or sale on pollution controlled vehicles.



360 MA-X

SMALL BLOCK

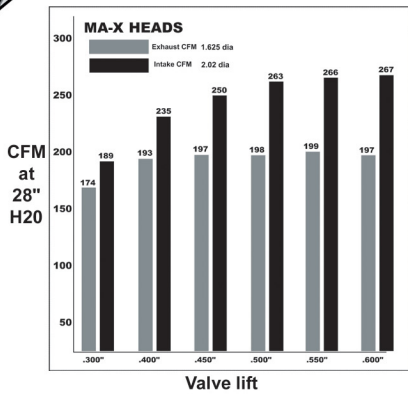

The 360 MA-X heads from Indy are true Magnum heads. The MA-X utilizes 100% Magnum style parts including pedestal mounted rockers, magnum bolt pattern intake manifolds and valve covers. The big advantage to the MA-X Head is the dual exhaust bolt pattern. Both stock Magnum as well as W-2 bolt patterns are machined into the head allowing for a much larger header selection

Standard Assembled Heads Feature:

- Brand new cast Iron MA-X castings.
- High flow 5/16 stainless valves 1.92x1.625.
- 2.02 and 2.055 Intake valves available.
- .525 Lift valve springs (.600 lift available).
- 3 Angle valve job.
- Chrome moly retainers .
- 7 degree locks.
- 179cc intake runner.
- 62cc combustion chambers.
- Upgrades & porting options are available.

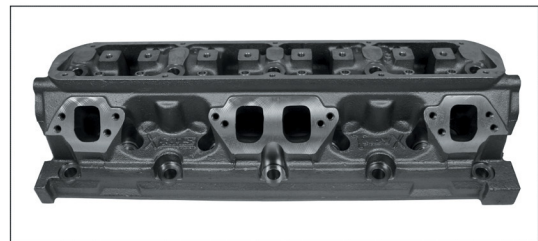
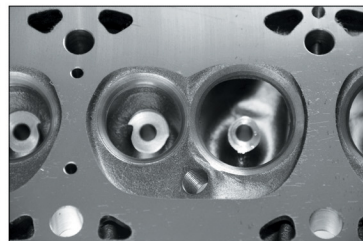
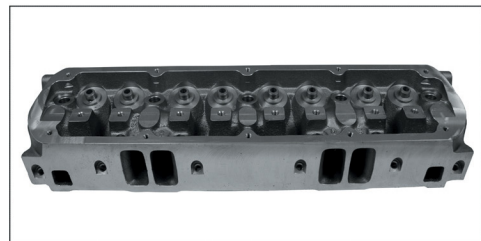
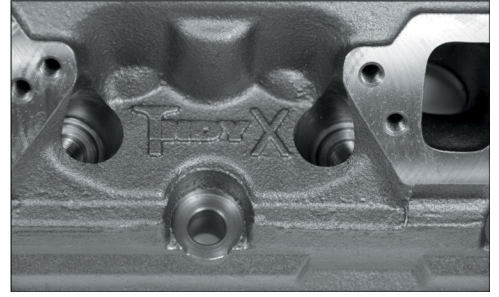
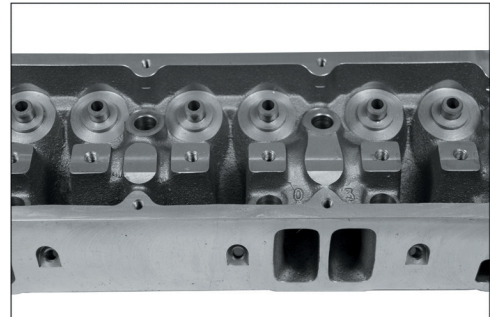
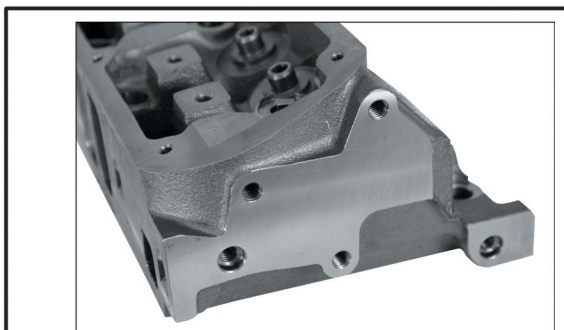

"Often Imitated...Never Duplicated" INDY T/A HEADS

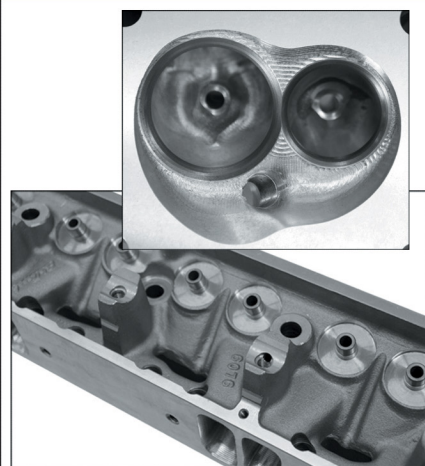

- An **Original** idea from ICH that others have failed to duplicate.
- The absolute best head for a stock configuration Chrysler small block engine.
- Lighter in weight, cools better and flows the best.
- 5/16 Stem light weight valve standard.
- 100% CNC ported T/A heads are available.

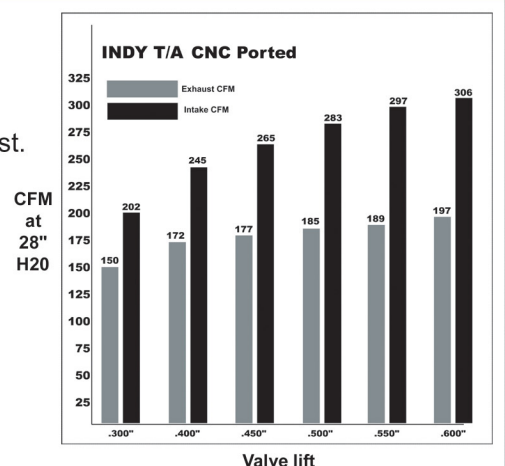
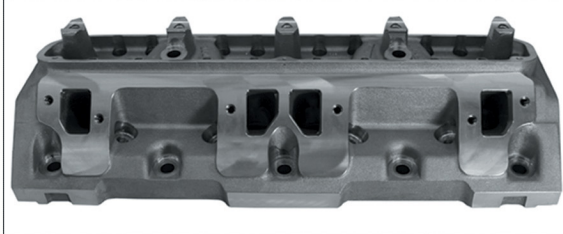

Call: 317-862-3724 Fax: 317-862-6300 Web: indyheads.com Email: techline@indyheads.com

Hemi is a trademark of the Chrysler Corporation and is used for identification purposes only. Not legal for use or sale on pollution controlled vehicles.