

PREDATOR

PREDATOR

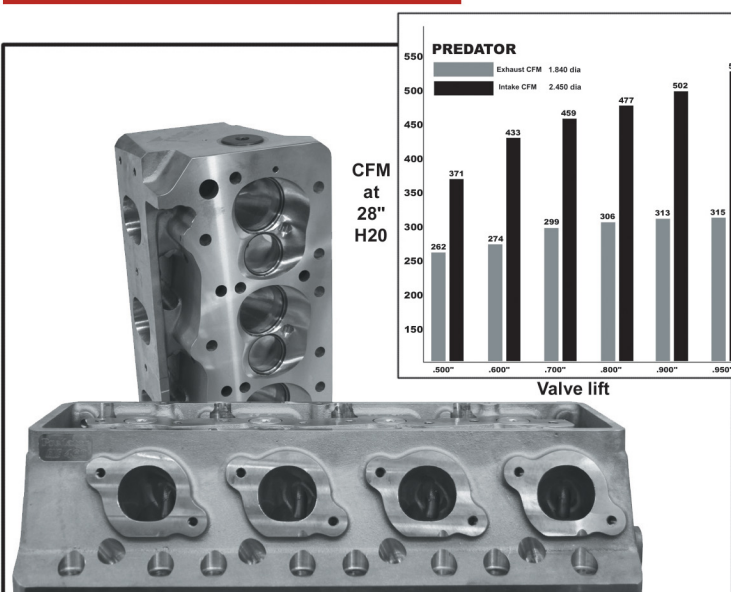

The Predator Head was developed in conjunction with Steve Gill to create the world's best cylinder head for the 4.800 centerline Chrysler engine. Available in both Hemi & Wedge head bolt patterns, the Predator is a symmetrically designed head to better equalize heat and make all runners and chambers exactly the same. Air flow numbers above 530cfm with a 2.450 intake valve and 460cc CNC porting are easily obtained.

Intake air enters the combustion chamber as far away from the exhaust valve as possible allowing for better cylinder fill and consequently more power. 1400 horsepower with a 655 cid top dragster engine is the standard at Indy.

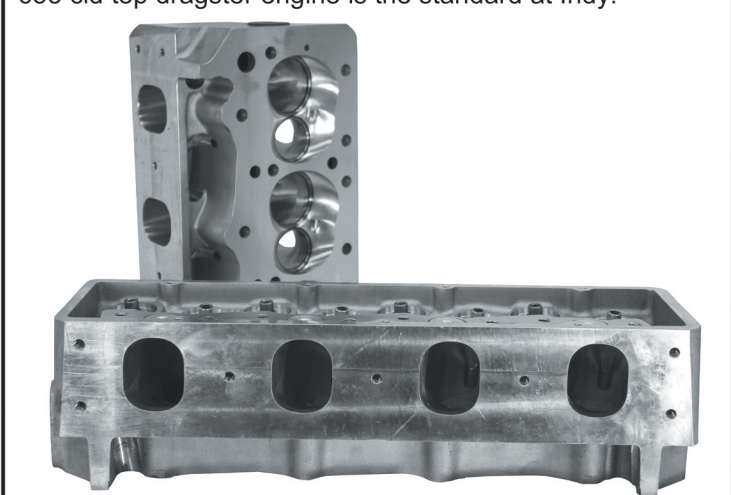

1400 HP Potential

- Can be purchased in both Pro and Semi Pro in kit form.
- Assembled heads come with roller springs good up to .980 lift.
- Customer must supply cam specs.
- Machined exclusively for special T&D rockers.
- Valve Angle is 10 degrees on the intake and 6 degrees on the exhaust.
- 540 CFM potential airflow.
- Intake port volumes available are 400cc as cast up to 460cc fully CNC ported.
- Exhaust port volume is 168cc.
- Intake valve diameter is 2.450.
- Exhaust valve diameter is 1.840.
- Titanium valves are optional.
- 84cc combustion chamber volume.
- Flat mill .006" per combustion chamber cc.
- Can be milled to 65cc.
- CNC combustion chambers available for 4.500 to 4.560 Bore.
- Use Indy Maxx block or Mopar World cast iron block.
- Wedge and Hemi head bolt patterns available.
- Bore centerline is 4.800.
- Spray bar valve covers (PRE-7S) or pushrod oiling available.
- 2.200 spring height, 1.625 common diameter.
- Head gasket: Cometic multi-layer steel.
- Intake Gasket: Indy 234P.
- Exhaust Gasket: Indy 238P.
- Head Studs: ARP PRE-17 for Wedge and PRE-27 for Hemi.
- Valve Guides: 11/32 solid bronze (5/16 available).
- 3/4 reach gasket seat spark plugs.
- Champion C57CX (cold) to C63CX (hot).
- To complete your engine Indy Cylinder Head manufactures big volume single 4500 and tunnel ram manifolds as well as light weight cast aluminum valve covers.
- Head stud torque 70ft lbs.
- 7/16-14 T&D rocker bolts 50ft lbs.



Call: 317-862-3724 Fax: 317-862-6300 Web: indyheads.com Email: techline@indyheads.com

Hemi is a trademark of the Chrysler Corporation and is used for identification purposes only. Not legal for use or sale on pollution controlled vehicles.



PREDATOR

PREDATOR

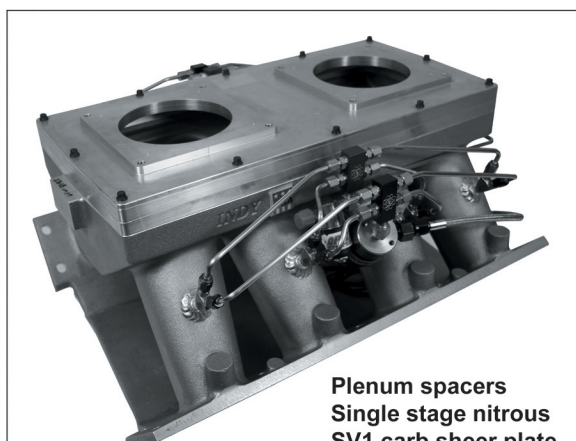

Plenum spacers
Single stage nitrous
SV1 carb shear plate



Tunnel base 27 lbs

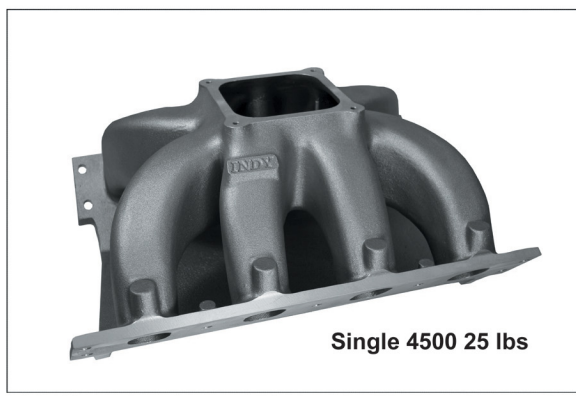

Single 4500 25 lbs

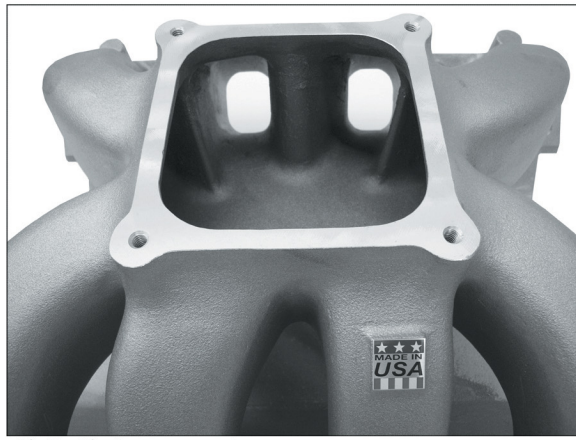

Valve covers
6 lbs each

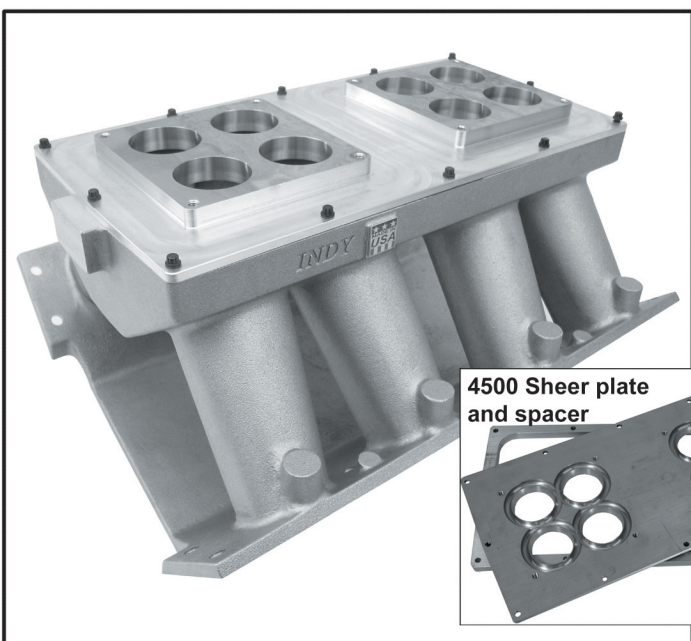

4500 Sheer plate
and spacer

Indy Cylinder Head completed the Predator project by designing lightweight cast aluminum manifolds and valve covers that are not only superior in performance, but affordable and user friendly for the engine builder. Indy Cylinder Head's in house pattern shop has developed a revolutionary lightweight casting process to produce cast aluminum versions of our previously designed fabricated sheet metal tunnel ram intake, large volume single 4500 intake, and superior sealing valve covers for the predator engine. Each manifold has cast in fuel injection bungs and fuel rail mounts. All fuel injection components can be installed by ICH or purchased separately from Indy Cylinder Head. The Predator combination is unchallenged in the world of performance as a cylinder head and air/fuel induction system.

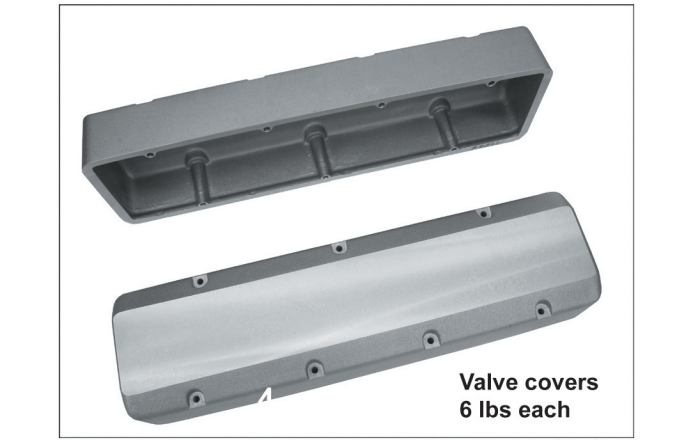

Valve covers
6 lbs each

Call: 317-862-3724 Fax: 317-862-6300 Web: indyheads.com Email: techline@indyheads.com

Hemi is a trademark of the Chrysler Corporation and is used for identification purposes only. Not legal for use or sale on pollution controlled vehicles.



Predator

317-862-3724
www.IndyHeads.com
info@IndyHeads.com

New Indy Predator Heads and Engines For The Ultimate in Performance

The Indy Predator Head

For the Big block B, RB and Hemi stock bolt patterns

Pro Predator Head Kit
Head Assembly w/ Hemi Pattern
Beryllium Seats Intake & Exhaust
Full CNC Porting 460cc Int Vol
CNC Chambers for 4.560 Bore
2.450 Int x 1.840 SS Val - 11/32
2.200 Height Roller Springs
Titanium Retainer - 10 deg Locks
Indy Cast Alum Valve Covers
Tunnel Ram Manifold 2x4500 Top
PR Oil Rocker Kit 1.8 x 1.8
ARP Head Stud Kit
Intake & Exhaust Gaskets
Valve Cover Gaskets
Total price... \$11,193.00

Semi Pro Predator Head Kit
Head Assembly w/ Hemi Pattern
Ductile Moly Seats Int & Exhaust
CNC Bowl port, CNC Port Match
CNC Chambers for 4.500 Bore
2.400 SS x 1.840 SS Val - 11/32
2.200 Height Roller Springs
Tit Retainers - 10 deg Locks
Indy Cast Alum Valve Covers
1x4 Big Volume 4500 Intake
PR Oil Rocker Kit 1.8 x 1.8
ARP Head Stud Kit
Intake & Exhaust Gaskets
Valve Cover Gaskets
Total price... \$9,220.00

Predator Options
Add for 440 bolt pattern... \$160.00
Add for Titanium exhaust valves... \$742.00
Tunnel ram plenum spacer 1/2"... \$135.00
SV-1 Top Plate... \$200.00
Add for spray bar installed... \$250.00
Add 454 external oil line... \$100.00

Predator Single Four Intake

4500 Carburetor
Cast in valley plate
Square top for Nitrous plates
Weights 24 lbs...\$1195.00

.060" Valve Cover Gaskets
Bosses for EFI or mechanical nozzles
.060" Intake Gaskets
Intake gaskets... \$20.00
Valve cover gaskets... \$25.00
Header gaskets... \$20.00

Predator Tunnel Ram
Built from sheet metal technology
Round tapered runners
Adjustable plenum volume
with 1/2" spacers
Cast in valley plate
Bosses for EFI or mechanical nozzles
Weights 29 lbs less top...\$1295.00

New Cast Predator Valve Covers

Only 5.4 pounds each
1/2" taller than sheet metal
\$315.00 set
Spray bars available
Add \$250.00

Indy Maxx Block
55MM Roller cam
Titanium valves
Race oil system-wet sump
Tunnel Ram 2-1250
Indy offset distributor
Dyno tested
Starting at
\$35,150.00

Add Jesel belt drive distributor \$730.00
Add 3 stage dry sump system \$1675.00
Add SV-1 Top Plate & Carbs \$1200.00

572" Predator Engine
1,000 HP-850 Torque
World Iron block Race oil system
Stainless valves 1150 Carb
Single four Dyno tested
Comp roller cam \$22,500

655" Predator Engine
1350 HP 1075 Torque
With Options

Shown with
dry sump oil system
and Jesel distributor

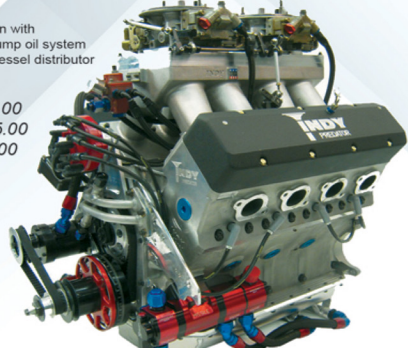

We Take
Indy
Head Engines
In On Trade

Indy Chrysler Distributors

Dual offset
MSD pickups
Adjustable phasing
(dual ignition box req'd)
\$1195.00

Single 1.750 Offset
MSD pickup
Adjustable phasing
\$795.00

Coming Soon!...Supercharger manifold for Predator heads

Indy Engines Powers Wheatcraft Racing To Many Finals



filter changes as the only maintenance necessary. Needless to say, this combination produced not only 1, but 2 championships. We captured the championships in both the Q16 and Super Pro and yes, this was with the same car entering it in 2 classes every race. Along the way, we were in 3 (2 wins and 1 runner up) out of 4 races at Pittsburgh Raceway Park all in one

weekend and also a runner up finish in the Paul Wilson Memorial Race. Outside of the Chrysler Classic many rounds were won and we were close to capturing the car's first \$10,000 bracket racing win when we lost in the 1/4 finals at Muncie Dragway's Firecracker Nationals. In addition, there was a weekend in

September when 21 passes were made in the car and 16 of them had an ET of 5.26 (1/8th mile) on the time slip. Thanks again to Indy Cylinder Head, and for any of you racers looking for a fast, reliable, consistent, low maintenance racing engine, you need to seriously consider Indy's 426-6.1/5.7 new legend hemi. - Ron Stayer, Jr. & Wheatcraft Racing.